

BIG BAG (rectangular)



Instructions for use

1. How to store filled Big Bags

Avoid storing Big Bags above 50° C when filled.

The filling slit (top) must be properly sealed.

Do not place any other items such as chemicals in cans etc., on top of Big Bags.

When storing outdoors please note:

- Big Bags should be covered with black plastic to prevent water from penetrating and to shield them from strong sunlight.
- Big Bags should not be placed on wet or damp ground.

2. Lifting filled Big Bags

Please check the following before lifting Big Bags:

- Look for any damage that might make lifting dangerous. Look for external wear and tear, cuts or other surface damage that could affect the strength of the bag. Exposure to direct sunlight and/or chemicals can cause damage to the material (e.g., discoloration), thereby considerably weakening the bag's structure.
- Lifting loops must be present.
- Make sure that the lifting device is capable of supporting the weight of the full Big Bag.
- Check the lifting arms of the fork-lift truck and ensure that these have rounded edges with a minimum radius of 5 mm. Blunt the edges by wrapping if necessary.
- Make sure that the distance between the hooks, bars or forks of the fork-lift truck is set to match the lifting loops.
- Make sure that the lifting mast of the fork-lift has been tilted backwards.

Avoid any jolting movements when lifting, lowering or transporting.

Do not start or stop suddenly. Make sure that the Big Bag does not collide with the arms of the forks. Do not drag the Big Bag along the ground.

3. Emptying the Big Bags



Electrostatically dissipative package. Package (inside and outside) and loops conceived to dissipate electrostatic charges.

Resistance to ground $R < 10^8 \Omega$. Earth at grounding loop during filling and emptying.

The contents of the Big Bag may be removed by vacuum or by simply allowing them to discharge while suspended. Do not walk in the area underneath the Big Bag once suspended. To open the discharge equipment untie the quick opening device (B-Look).

Blowing out the Big Bag is only possible at workstations equipped with suitable filters, as this creates excessive dust.

Take suitable precautions against any dust. More information can be obtained here: www.hoffmann-mineral.com/Health-and-Safety/Occupational-Protection.

4. Material and measurements

The Big Bag is made of laminated polypropylene.

Depending on your requirements we offer you two types of conductive Big Bags:

Type 4:

Headroom required:
2950 mm (116.1");
Height on pallet:
1310 mm (51.6").

Type 9:

Headroom required:
3740 mm (147.2");
Height on pallet:
2100 mm (82.7").

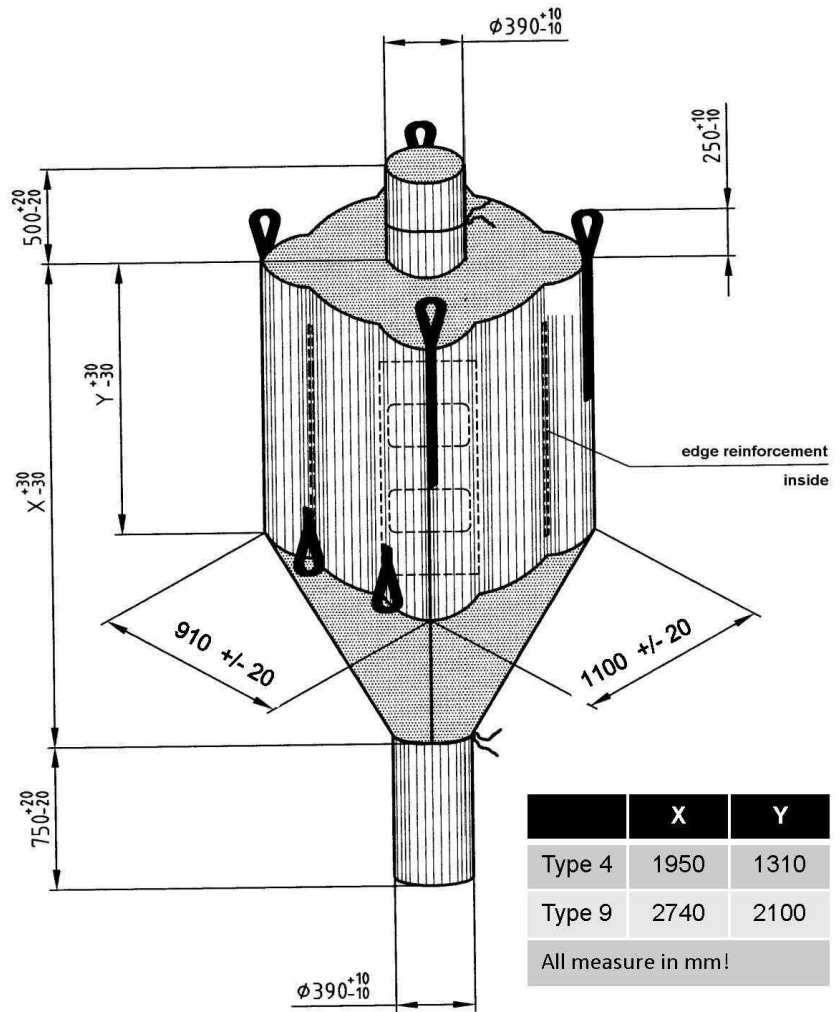

5. Packaging



Product	Type 4	Type 9
SILLITIN V 85 SILLITIN V 88 SILLITIN N 82 SILLITIN N 85 SILLITIN N 87	≤ 750 kg	≤ 1200 kg
SILLITIN Z 86	≤ 600 kg	≤ 1000 kg
SILLITIN Z 89 SILLIKOLLOID P 87	≤ 550 kg	≤ 900 kg
AKTISIL VM 56 AKTISIL MAM AKTISIL MAM-R AKTISIL EM, AM, MM AKTISIL VA, Q AKTISIL PF 216 AKTISIL PF 777	≤ 550 kg	≤ 900 kg
SILFIT Z 91 AKTIFIT AM AKTIFIT VM	≤ 600 kg	≤ 900 kg

Our applications engineering advice and the information contained in this memorandum are based on experience and are made to the best of our knowledge and belief, they must be regarded however as non-binding advice without guarantee. Working and employment conditions over which we have no control exclude any damage claim arising from the use of our data and recommendations. Furthermore we cannot assume any responsibility for patent infringements, which might result from the use of our information.